

## EUROPEAN QUALIFYING EXAMINATION 2019

# Paper A

This paper comprises:

- |                               |                 |
|-------------------------------|-----------------|
| * Letter from the applicant   | 2019/A/EN/1-7   |
| * Drawings of the application | 2019/A/EN/8     |
| * Document D1                 | 2019/A/EN/9-10  |
| * Document D2                 | 2019/A/EN/11-12 |



**Letter from the applicant**

CELLabrate Ltd., Kidlington, Oxfordshire, United Kingdom

5 Dear Ms Organa,

10 [001] Our company designs and manufactures devices which are used for growing cells in laboratories. We are currently travelling to a meeting with a potential customer in Japan who is interested in our technology. Before we meet them, we would like to protect our ideas in a patent application. Unfortunately, we will all be on the flight to Japan for the next 12 hours, and so will not be available to answer any questions. I have therefore enclosed all the information you will need to draft and file the application today. I have also attached two documents (D1 and D2) which you may find helpful for understanding the background to our invention. Please note that in accordance with our  
15 company policy we will not pay any additional claims fees.

20 [002] In order to successfully grow cells in culture, i.e. in a laboratory, it is necessary to supply the cells with the essentials for growth and respiration. Cells derived from animals or humans are normally grown in a liquid medium which contains all the necessary nutrients. The cells are usually grown under controlled conditions including pH, temperature and exchange of gases such as oxygen (O<sub>2</sub>) and carbon dioxide (CO<sub>2</sub>) with the surroundings. Cell culture devices are typically kept in an incubator in which oxygen is supplied at about 20% concentration, to ensure that the cells can obtain sufficient oxygen for adequate growth.



[003] In conventional cell culture devices such as multi-well plates (see D1), the supply of oxygen comes from the space in the container above the surface of the cell culture medium, known as the head space. Thus the surface provided for gas exchange is limited and may result in low rates of cell growth. Further, there may be a sharp initial drop in pH within the first hour or two caused by carbon dioxide from the head space dissolving in the medium. This drop in pH can negatively affect the rate of cell growth.

[004] The invention overcomes these problems by providing a device for culturing cells comprising a first and a second gas-permeable membrane. The gas-permeable membranes are held by a frame in order to form a cell culture chamber between the two opposing membranes and the frame. The term "gas-permeable" means that the membrane contains pores that allow gases to pass through it. The use of a gas-permeable membrane enables an increased exchange of gases, in particular CO<sub>2</sub> and O<sub>2</sub>. It is the aim of the invention to increase the exchange of gases and therefore to increase the cell growth rate.

[005] In order to prevent the cell culture medium from leaking out of the device it is essential that the gas-permeable membranes are liquid-impermeable. For the same reason the membranes must be attached to the frame of the device by means of a leak-proof seal. We have found it advantageous to use a gas-permeable and liquid-impermeable membrane which is optically transparent, to permit observation of the cells. There are many different types of commercially available membranes that can be used, e.g. membranes comprising polymers such as polyethylene, polycarbonate, polypropylene or a silicone copolymer. The choice of polymer will depend on the type of cell to be grown, the rate of gas transfer and optical transparency.



[006] We have found that gas-permeable membranes comprising polyethylene provide a really good combination of features for cell culture. We have further found that at normal atmospheric pressure ( $=10^5$  Pa) and at 37°C membranes with a gas permeability performance of from  $1 \times 10^{-16}$  to  $3 \times 10^{-16} \text{ m}^3/(\text{s}\cdot\text{Pa})$  for  $\text{O}_2$  and from  $6 \times 10^{-16}$  to  $7 \times 10^{-16} \text{ m}^3/(\text{s}\cdot\text{Pa})$  for  $\text{CO}_2$  result in excellent rates of cell growth. Membranes classified in these ranges of gas permeability are well-known and available on the market.

[007] Cells of a certain type, known as adherent cells, require attachment to a surface in order to grow. Therefore, some clients request that we coat the inner surface of one or both gas-permeable membranes with a substance that facilitates cell adhesion. Various different types of coating are available on the market for this purpose, and include molecules such as gelatine, collagen and fibronectin.

[008] We have tried various ways of using gas-permeable membranes in devices for cell culture. Our most commercially promising approach consists of a device as shown in Figs. 1a -1c.

Fig. 1a shows a view from above onto the cell culture device.

Fig. 1b shows a side view of the cell culture device.

Fig. 1c shows a cut through the cell culture device along the cross-section A-A drawn in Fig. 1a.

The device has a first gas-permeable membrane 2a and a second gas-permeable membrane 2b which are held by a frame 1 in order to form a cell culture chamber 4 between the two opposing membranes 2a, 2b and the frame 1. The use of two gas-permeable membranes 2a, 2b on opposite sides of the frame increases the surface area available for gas exchange between the culture and the incubator. The device also has at least one leak-proof resealable aperture 3a, 3b through the frame 1 that allows substances to be introduced into or withdrawn from the culture chamber.



[009] We have been able to manufacture this device in a variety of shapes and sizes to suit the needs of our customers. However, we have found that providing an average distance of about 1 mm to 5 mm between the membranes provides the optimum amount of space for the cells to grow and still have sufficient gas exposure.

5

[010] The frame can be made of any material that has the required structural integrity to keep the device relatively rigid and that is suitable for contacting the cells. For example, the frame may be made from a biocompatible composition that comprises a suitable plastic or thermoplastic. The dimensions of the frame will depend at least in part on the type of material used. We usually make the device rectangular in shape, so that it can be easily held in place by a standard specimen holder for a microscope. For the same reason, most of our devices are about 10 cm to 15 cm long, about 7 cm to 9 cm wide and about 0.2 cm to 2 cm high, with the membranes each having a thickness of 0.05 mm to 0.15 mm.

15

[011] Using two membranes 2a, 2b and a frame 1 for forming the cell culture chamber 4 has the drawback that the liquid medium and the cells cannot be introduced or withdrawn merely by opening the lid as described in D1. It is therefore essential that a leak-proof resealable opening is present in the cell culture device. Two alternative design solutions are possible for a leak-proof resealable opening: either the frame comprises at least one leak-proof resealable aperture 3a, 3b as described above, or at least one membrane 2a, 2b is a leak-proof resealable membrane as described in D2. Therefore, in order to carry out the invention, the frame of the cell culture device comprises at least one leak-proof resealable aperture 3a, 3b or/and at least one membrane 2a, 2b is resealably attached to frame 1 in a leak-proof manner.

20

25



[012] First embodiment: The leak-proof resealable apertures 3a, 3b allow the user to introduce the liquid medium and cells into the device and then withdraw them once the cell culture process is complete. To make sure that the device does not leak, the aperture 3a, 3b has to be leak-proof resealable, so that it can be securely closed after  
5 being opened. We prefer to use a gasket, which is a type of mechanical seal. When a needle tip is inserted into the gasket, it closes around and engages the tip to form a leak-proof seal, and reseals itself after the tip is withdrawn. Ideally the gasket is made of an elastomeric material which can easily be deformed and then spring back. The elastomeric material may be natural, such as natural rubber, or synthetic, such as  
10 silicone rubber or fluorocarbon rubber.

[013] The aperture 3a, 3b is also a potential route for infection of the cell culture by microbes in the surrounding area. We have therefore found it is advantageous to use a gasket comprising an elastomeric material together with an antimicrobial agent  
15 integrated therein. There are many different antimicrobial agents on the market that could be used, such as triclosan or chloroxylenol.

[014] It is useful to have two or more apertures 3a, 3b in the frame, as this allows the user to introduce substances into the culture chamber (such as fresh medium) via one  
20 aperture 3a, while other substances (such as air or spent medium) are removed via the other aperture 3b. Most of our clients use a standard-size needle and syringe to access the cell culture chamber. Therefore it is advantageous that each aperture has a diameter, generally about 1 mm to 2 mm, sufficient for standard needles to pass through. It is also preferable to make the frame of sufficient thickness and the one or  
25 more apertures of a sufficiently limited diameter to prevent the tip of the needle from contacting and puncturing either of the membranes.

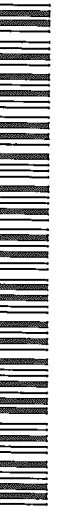

- [015] When an aperture 3a, 3b in frame 1 is used as leak-proof resealable opening, it is essential that both membranes 2a, 2b are sealed to frame 1 in a manner that prevents the liquid medium from escaping. The membranes can be fixed to the frame using an adhesive, such as a hot-melt adhesive. However, our preference is that each membrane
- 5 is secured to the frame by ultrasonic welding, i.e. melting the membrane to the frame in a manner that results in a leak-proof seal between the membrane and the frame. We think that these methods of manufacturing the cell culture device could be commercially interesting.
- 10 [016] Second embodiment: Instead of an aperture in the frame, alternatively one membrane 2b can be made leak-proof resealable, to allow the device to be opened and resealed multiple times. This allows easier removal of samples from the cell culture or addition of liquid cell culture medium.
- 15 [017] If the leak-proof resealable opening is realised by means of a leak-proof resealable membrane 2b, we have to use different adhesives for attaching the leak-proof resealable membrane to the frame, compared to the first embodiment. For the second embodiment it is essential that the adhesive is pressure-sensitive, so that when the leak-proof resealable membrane is pressed back onto the frame it forms a leak-proof seal.
- 20 The pressure-sensitive adhesive does not leave behind a sticky residue when the leak-proof resealable membrane is removed from the frame and so allows multiple openings and closings of the membrane. Various different types of pressure-sensitive adhesive are commercially available and all those we have tested have worked adequately.



[018] Third embodiment: The first and second embodiments can also be combined such that the frame comprises at least one leak-proof resealable aperture 3a, 3b and a membrane 2b is resealably attached to frame 1 in a leak-proof manner using a pressure-sensitive adhesive.

5

[019] Using two opposing membranes 2a, 2b and a frame 1 for forming the cell culture chamber 4 allows only the three embodiments described above. For the second and third embodiment it is essential that the adhesive is pressure-sensitive. For all three embodiments it is advantageous that the first and second membranes have direct contact to air in order to allow gas exchange. This may be realised by a rack which can hold the device in the incubator so that there is sufficient space between each membrane and the incubator to allow air to circulate.

10

[020] As explained above, the device can be used in a method of culturing cells. A typical method of cell culture in our device involves the following steps:

15

- (a) suspending the cells to be cultured in an appropriate amount of cell culture medium to form a cell suspension;
- (b) introducing the cell suspension into the cell culture device;
- (c) incubating the cell culture device containing the cell suspension in conditions allowing cell growth.

20

[021] When a particularly high rate of cell growth is required, the cell culture chamber may be completely filled with the cell suspension such that there is no head space containing air. In this way it is possible to prevent a drop in pH caused by dissolved CO<sub>2</sub> from the head space. Furthermore, when the culture chamber is completely filled with suspension, the device can be tilted or gently shaken without causing formation of foam which may disrupt the cell growth.

25

Yours sincerely,

30 Mr B. Kenobi





Drawings of the application

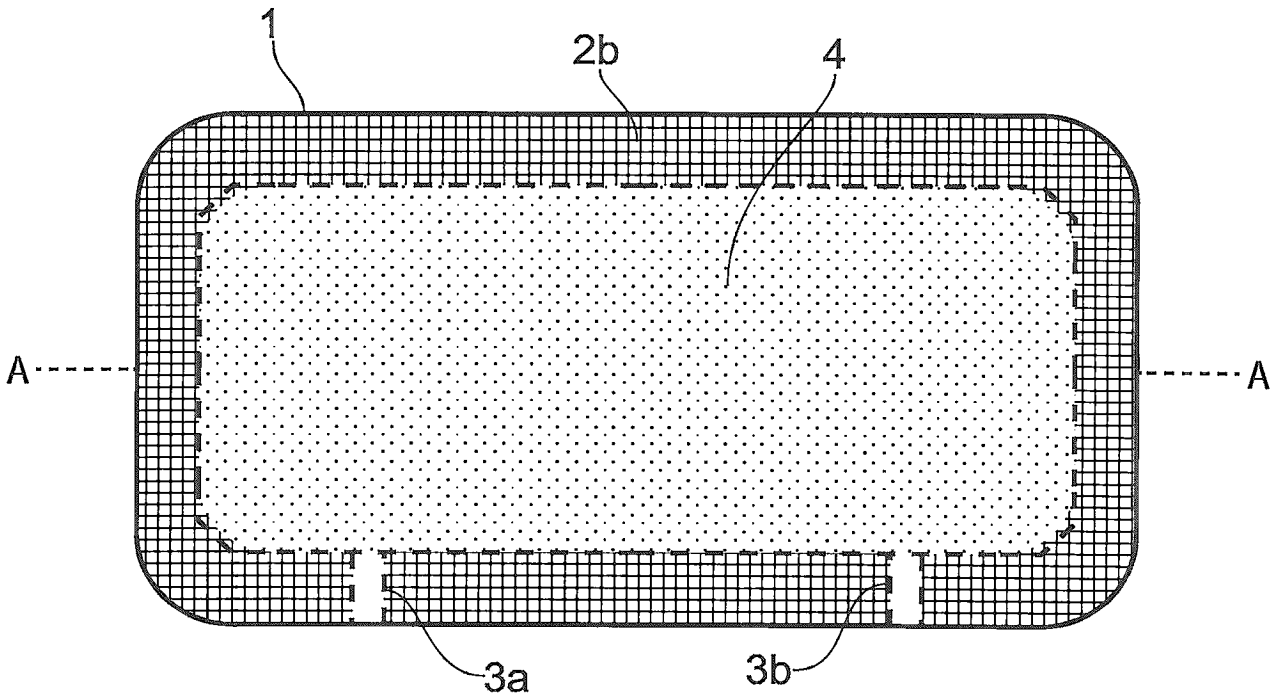

Fig. 1a

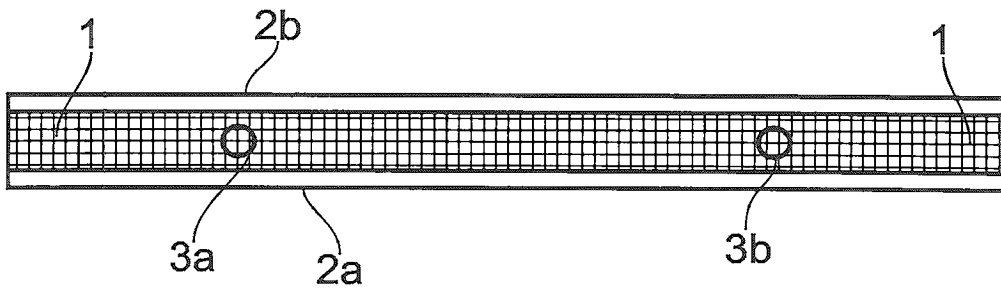

Fig. 1b

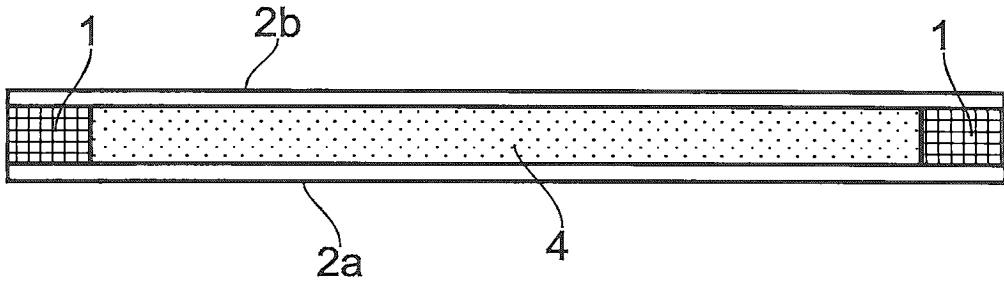

Fig. 1c



**Document D1**

**Textbook excerpt**

5 [001] Cell culture is defined as the removal of cells from their natural environment and their subsequent growth in an artificial environment. Suitable artificial environments typically consist of a container containing a cell culture medium that supplies the essential nutrients for growth. The cells also require various gases, in particular carbon dioxide (CO<sub>2</sub>) and oxygen (O<sub>2</sub>). Cells are grown and maintained in a cell incubator at an appropriate temperature and in an appropriate gas mixture.

10

[002] A conventional container in the form of a multi-well plate is shown in Fig. 1. The plate 11 consists of a flat surface comprising a series of wells 12 which hold the cell culture medium and cells. During use, the wells are covered with an airtight lid 13 which attaches securely and seals the wells shut. Both the plates and lids are typically made from a rigid, airtight plastic such as polystyrene. The plates and lids are also optically transparent, to allow observation of the cells during culture. One or more surfaces of the wells may be treated in order to allow attachment of adherent cells, for example by coating the surface with a substance such as collagen.

20 [003] Single wells 12 may have to be refilled with liquid medium without disturbing the cell growth in other wells. For this purpose a leak-proof resealable aperture may be designed in the lid or in the plate, allowing individual access to the single wells. Instead of a rigid lid a gas permeable membrane may be used. Such a membrane is available on the market under the product name GasEasy™.



[004] The optimum conditions for cell culture will differ for each type of cell. However, all cell culture methods involve the same basic steps, as follows:

- (a) suspending the cells to be cultured in an appropriate amount of cell culture medium to form a cell suspension;
- 5 (b) introducing the cell suspension into the cell culture vessel;
- (c) incubating the cell culture vessel containing the cell in conditions allowing cell growth.

Cell growth conditions, such as appropriate temperature and pressure, are well-known in the art.

10

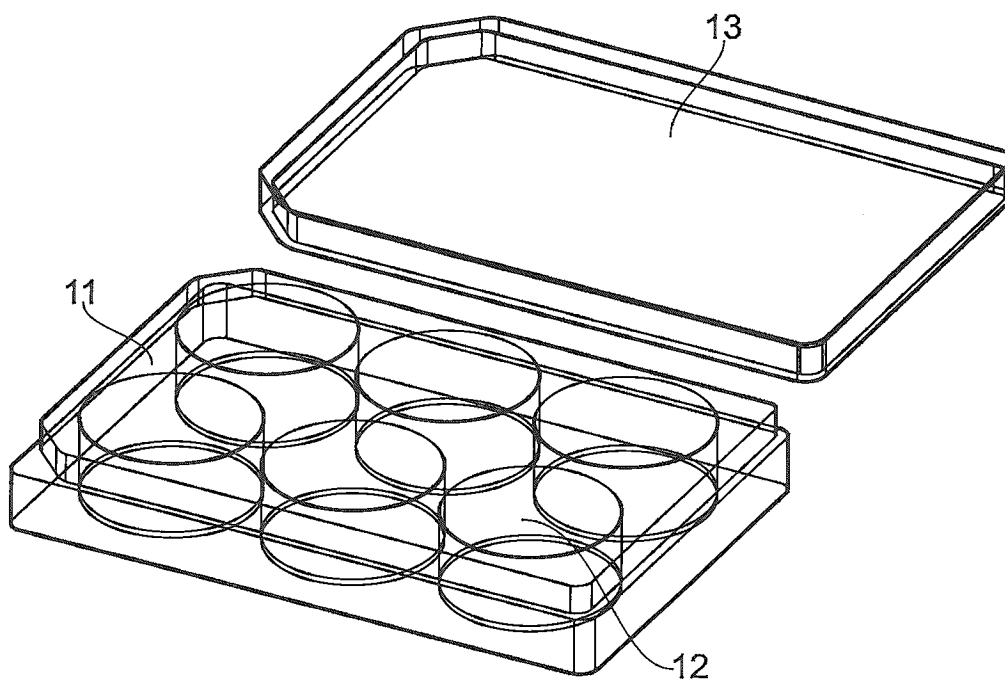

Fig. 1



**Document D2**

**Product leaflet**

5 [001] The GasEasy™ sealing film provides a simple and effective way of allowing gases into cell cultures while providing a barrier against contamination. GasEasy™ is an adhesive, gas-permeable and liquid-impermeable membrane that can be used to seal the openings of a cell culture container. The film does not leave a sticky residue behind when it is removed, allowing the opening to be opened and reclosed multiple times in a leak-proof manner.

10

[002] GasEasy™ films allow for rapid, uniform gas exchange of oxygen and carbon dioxide for optimum cell growth. They are highly gas-permeable, with a gas permeability performance at atmospheric pressure ( $10^5$  Pa) and at 37°C of about  $1.5 \times 10^{-16} \text{ m}^3/(\text{s}\cdot\text{Pa})$  for  $\text{O}_2$  and about  $6 \times 10^{-16} \text{ m}^3/(\text{s}\cdot\text{Pa})$  for  $\text{CO}_2$ .

15

[003] GasEasy™ is made from a membrane comprising polyethylene which is designed to be stable at a range of temperature conditions. It is also easy to take off and replace the film, allowing for simple removal of samples from the cell culture or addition of cell culture medium. The film is flexible and completely transparent. Because the GasEasy™ membrane is impermeable to liquids, it also prevents spillage of the cell culture medium.

20

[004] GasEasy™ is ideally suited to leak-proof sealing multi-well plates, as shown in Fig. 1. It is sufficient to apply the adhesive film or films over the surface of the plate and press down to seal around the edge of each well. To ensure a leak-proof seal, apply with a firm and even pressure. A hard rubber roller can be used for this purpose. In the case of large multi-well plates, it is possible to use several films juxtaposed next to each other.

25



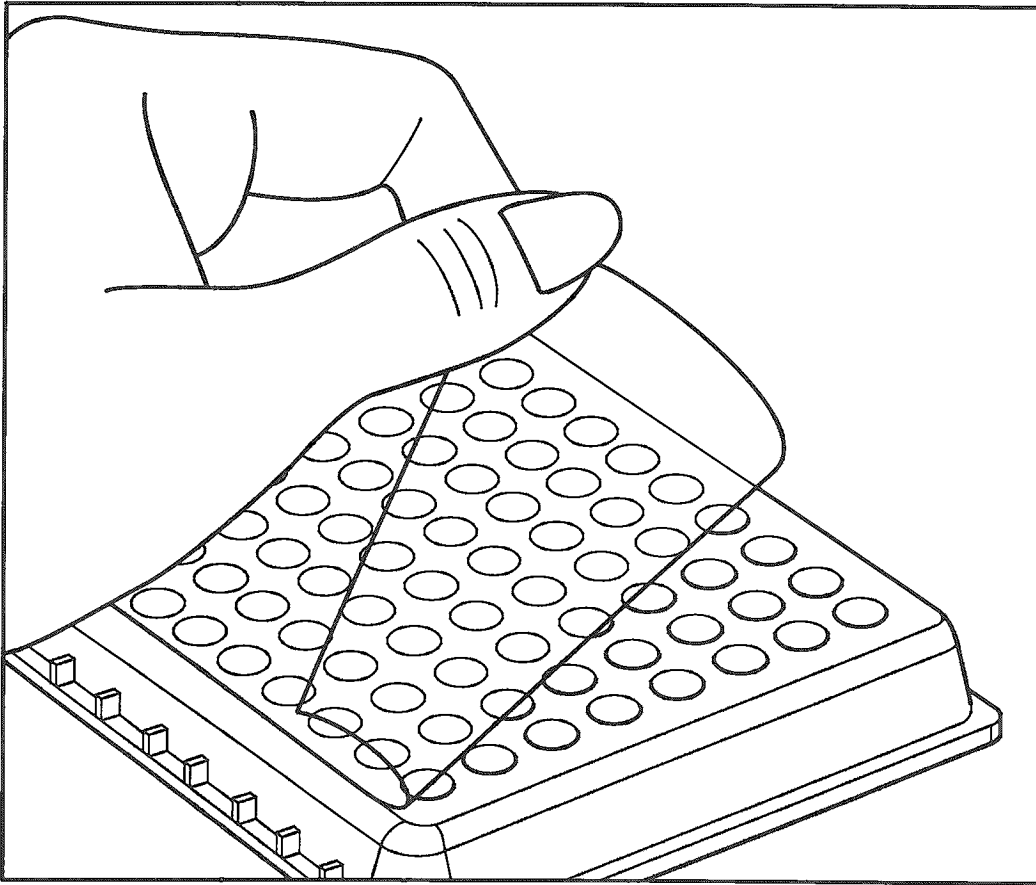

Fig. 1

